



Europäisches Patentamt
European Patent Office
Office européen des brevets



Publication number: **0 470 615 A1**

EUROPEAN PATENT APPLICATION

Application number: **91113326.2**

Int. Cl.⁵: **H01H 13/70, G06F 3/023**

Date of filing: **08.08.91**

Priority: **09.08.90 JP 85019/90**

Date of publication of application:
12.02.92 Bulletin 92/07

Designated Contracting States:
DE ES FR IT SE

Applicant: **NINTENDO CO., LTD.**
60, Fukuinekamitakamatsu-cho,
Higashiyama-ku
Kyoto-shi, Kyoto-fu(JP)

Inventor: **Inoue, Yoshihiro**

8-8-4, Nishiura-cho, Fushimi-ku
Kyoto-shi, Kyoto-fu(JP)
Inventor: **Ashida, Kenichiro**
1-5-22, Minaminanamatsu-cho
Amagasaki-shi, Hyogo-ken(JP)

Representative: **Altenburg, Udo, Dipl.-Phys. et**
al
Patent- und Rechtsanwälte
Bardehle-Pagenberg-Dost-Altenburg-Frohwi-
tter & Partner Postfach 86 06 20
W-8000 München 86(DE)

Controller for a game machine.

A controller (10) for a game machine includes a flat shaped housing. A direction designating operator (12) is formed on the left side of upper surface of housing, and operation designating operator (13) is formed on the right side. An operation designating operator (14) is provided on a front side surface of the housing. The operation designating operator includes a key switch (14a) formed on the left side of a front side surface of housing, and a key switch (14b) formed on the right side. Left and right ends of the controller for a game machine are held between left and right palms to be used. While holding con-

troller for a game machine, a player operates direction designating operator by his left thumb, operates operation designating operator by his right thumb. Further, player operates key switch by his left index finger or middle finger placed on the front side surface of housing, and operates key switch by his right index finger or middle finger. In this manner, various and many switches of the controller for a game machine of the present invention can be operated, with very little movement of hands of a player holding the controller.

FIG. 6

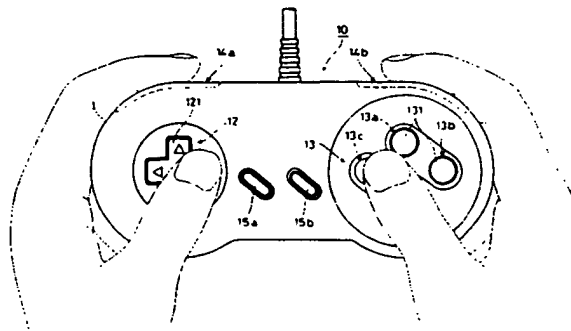

EP 0 470 615 A1

BACKGROUND OF THE INVENTION

Field of the Invention

The present invention relates to a controller for a game machine and, more specifically, to a controller used by a player for operating a video game machine.

Description of the Background Art

A controller for a TV game machine for home use (commercially available as "Family Computer" and "Nintendo Entertainment System") which is manufactured and sold by the assignee of the present invention has been well known as a controller for a game machine (or a game machine operating apparatus). This controller comprises a cross shaped key top and provided on an operation surface of a housing, and a rubber contact switch provided therebelow, as disclosed in U.S. Patent No. 4,687,200 or in Japanese Utility Model Registration No. 748986. By this controller, four different instructions can be given to the game machine only by moving a thumb placed on the key top upward, downward, to the left and to the right, and it can be operated easily.

However, since recent game programs have become more complicated and difficult, the number of operation switches have been increased. When the number of operation switches are increased, different switches must be simultaneously operated by plural fingers, and therefore speed of operation tends to be decreased, and miss operation may occur. Such problems make the game less interesting.

Therefore, when the number of operation switches is to be increased, design of a controller is of much importance. The following conditions must be satisfied to provide good controllability even if the number of operation switches are increased, from the view point of human engineering.

- (1) It is not necessary to move one's hand as a whole to operate a switch.
- (2) A switch can be depressed with minimum movement of a finger.
- (3) Direction of movement of a finger is natural and accordant with movement of the joint of one's finger.
- (4) As to the index finger or middle finger which can be moved in narrower range compared with the thumb, only one switch is allotted to one finger, and the key top for the finger is large.
- (5) The controller can be fixed when held by both hands.
- (6) The controller is light and compact so that it is easy to hold the controller by both hands.
- (7) The controller has durable structure enough

to withstand frequent and rough treatment.

Unfortunately, an ideal controller for a game machine satisfying all conditions described above has not yet been realized.

SUMMARY OF THE INVENTION

Therefore, an object of the present invention is to provide a controller for a game machine which is quite easy to handle and enables quick and correct operation even if the number of operation switches is increased.

Another object of the present invention is to provide a controller for a game machine having simple structure and suitable for mass production.

A further object of the present invention is to provide a controller for a game machine having durable structure enough to withstand frequent and rough handling.

The controller for a game machine in accordance with the present invention is held between left and right palms, and includes a flat shaped housing, upper surface operating means and side surface operating means. The housing includes an upper surface, a lower surface and a side surface spatially separating the upper and lower surfaces. The upper surface operating means is formed on the upper surface of the housing where a thumb of a hand holding the housing can reach. The side surface operating means is formed on the side surface of the housing where an index finger or middle finger of the hand holding the housing can reach. The side surface operating means includes an elongate key top, switching means, and holding means. The key top is axially supported in the housing and rotatable. It is arranged such that a portion thereof is exposed along the side surface of the housing. The switch means is contained in the housing, and when it is depressed by the rotation of the key top, it outputs an electric signal. The holding means holds the switch means in the housing at a position where the switch can be depressed by the key top.

In the present invention, the upper surface operating means is formed on the upper surface of the housing where a thumb can reach, and the side surface operating means is formed on the side surface of the housing where an index finger or middle finger can reach. Therefore, a user can operate respective operating means simply by moving the thumb and the finger without moving his hand holding the housing. In addition, each of the operating means can be operated with minimum movement of the thumb or the finger. In addition, in the present invention, directions of depressing the upper surface operating means and the side surface operating means are the same as the directions of bending the thumb or the finger

operating these means, and therefore, smooth operation is enabled. Further, in the present invention, the key top of the side surface operating means has an elongate surface and arranged along the side surface of the housing. Therefore, a wide operating range can be ensured below the index finger or the middle finger holding the side surface of the housing. Therefore, even if this operating means is operated by an index finger or the middle finger which has smaller range of movement and slow speed of operation compared with the thumb, it can be easily operated. Further, in the present invention, the switching means of the side surface operating means is held by the holding means in the housing. Therefore, it can withstand frequent and rough handling. Since the housing of the controller has a flat shape, it is light and compact and it can be easily held by both hands. Further, since the present invention has simple structure, assembly is easy and it is suitable for mass production.

As described above, the controller for a game machine in accordance with the present invention fairly satisfies the above conditions (1) to (7). The controller for a game machine in accordance with the present invention has superior controllability, it is inexpensive and durable.

The foregoing and other objects, features, aspects and advantages of the present invention will become more apparent from the following detailed description of the present invention when taken in conjunction with the accompanying drawings.

BRIEF DESCRIPTION OF THE DRAWINGS

Fig. 1 is a perspective view of a controller for a game machine in accordance with one embodiment of the present invention, viewed from an upper surface.

Fig. 2 is a perspective view of the controller for a game machine in accordance with one embodiment of the present invention, viewed from the lower surface.

Fig. 3 is a fragmental perspective view of the controller for a game machine in accordance with one embodiment of the present invention, viewed from the lower surface.

Fig. 4 is a cross sectional view of the controller for a game machine in accordance with one embodiment of the present invention.

Fig. 5 is a vertical sectional view of a main portion of the controller for a game machine in accordance with one embodiment of the present invention.

Fig. 6 illustrates state of operation of the controller for a game machine in accordance with one embodiment of the present invention.

Fig. 7 is a block diagram showing one example of a structure of a game machine system to which

the controller for a game machine of one embodiment of the present invention is connected.

DESCRIPTION OF THE PREFERRED EMBODIMENTS

Figs. 1 and 2 are perspective views of the appearance of the controller for a game machine in accordance with one embodiment of the present invention. Fig. 1 shows a state viewed from the upper surface of the controller for a game machine, and Fig. 2 shows a state viewed from the lower surface.

Referring to Figs. 1 and 2, a controller 10 for a game machine includes a housing 11. A direction designating operator (also referred to as a direction designating switch) 12 which is an example of a first upper surface operating means, and an operation designating operator (also referred to as an operation designating switch) 13 which is an example of second upper surface operating means are separately provided at the left and the right of the upper surface of housing 11. The arrangement of direction designating operator 12 and operation designating operator 13 may be reversed. At least one operation designating operator (also referred to as an operation designating switch) 14 which is an example of the side surface operating means which is the characteristic of the present invention, is provided on the side surface of housing 11 positioned in front of direction designating operator 12 or operation designating operator 13.

More preferably, a pair of (a total of two) operation designating operators 14 are provided in the left and right positions of the front side surface of the housing 11. In the figure, two operation designating operators are provided, one of which is designated by 14a and another by 14b. The operation designating operator 14 is used for designating a state of operation (for example, state of operation of a character in a video game machine) different from that of the operation designating operator 13.

Further, a select switch 15a and a start switch 15b are provided in the middle of direction designating operator 12 and operation designating operator 13 on controller 10 for the game machine.

Figs. 3 to 5 show details of the controller in accordance with one embodiment of the present invention. Fig. 3 is a fragmental perspective view of the controller viewed from the lower surface, Fig. 4 is a cross section, and Fig. 5 is a vertical sectional view of the main portion.

More detailed structure of controller 10 will be described in the following with reference to Figs. 1 to 5. Housing 11 is divided into an upper half 111 and a lower half 112. Housing 11 has a flat longitudinal shape. Left and right side surfaces of housing 11 are rounded, so that a user can hold it easily.

The central portion of the rear side surface of housing 11 has a concave in the direction of the front side surface so as to facilitate movement of thumbs operating direction designating operator 12 and operation designating operator 13. More preferably, the upper surface of housing 11 has a smooth carved convex shape, and the lower surface has a smooth carved concave shape as shown in Fig. 5, so as to be stable when it is held by both hands, and to fit players hands to facilitate operation.

A switch disclosed in, for example, U.S. Patent No. 4,687,200 is used as direction designating operator 12. More specifically, direction designating operator 12 includes a cross shaped key top 121. A rubber contact 123 constituting four contacts 122 is arranged below key top 121. Rubber contact 123 is placed on a board 16 on which a contact circuit (not shown) is formed. When any of an upper, lower, left and right projecting portion of key top 121 is depressed, rubber contact 123 therebelow is resiliently deformed in the direction of depression of the key top 121. Consequently, contact 122 positioned below the direction of depression of key top 121 out of four contacts 122 of rubber contact 123 is brought into electrical contact with the contact circuit formed on board 16. Direction designating operator 12 having such a structure serves as a switch designating one of the upper, lower, left and right directions. A cross shaped hole 113 into which key top 121 is inserted is formed on the upper surface near the left end of the upper half 111.

Operation designating operator 13 includes four key switches 13a to 13d. These key switches 13a to 13d are provided at the upper surface near the right end of housing 11. Key switches 13a to 13d are positioned to be on two lines crossing with each other. The two lines may orthogonally cross each other. Each of key switches 13a to 13d has a cylindrical key top 131. A projection 132 projecting radially is formed on the outer periphery of a base portion of each key top 131. Four holes 114 into which key tops 131 are inserted are formed on the upper half 111. At the rear surface of upper half 111, a cylindrical guide projection 115 is formed around each hole 114. A groove 116 for guiding projection 132 provided on each key top 131 is formed on the side surface of each guide projection 115. Instead of such groove 116, stripe notches may be provided on inner wall of the side surface of each guide projection 115. A rubber contact 133 for resiliently holding each key top 131 is provided below each key top 131. Rubber contact 133 is formed of an elastic rubber on which four contacts 134 corresponding to the key tops 131 are integrally fixed. At portions of the board 16 positioned below each key top 131, a contact cir-

cuit (not shown) corresponding to each contact 134 of the rubber contact 133 is formed. A cord 17 for transmitting states of operations of various switches 12, 13, 14, 15a and 15b (see Fig. 7) to a processing unit (CPU) is connected to the board 16, and a signal processing circuit 18 shown in Fig. 7 is provided on the board 16.

Designations given by key switches 13a to 13d to the body of the game machine (not shown) in response to operations thereof are determined by the game program. Contents of designation of key switches 13a to 13d are not fixed on the side of the controller. Therefore, controller 10 treats key switches 13a to 13d as switches designating operation A to operation D, the function of which is not specified. Reference characters A to D are allotted to surfaces of key tops 131 of key switches 13a to 13d or to positions of the upper surface of upper half 111 corresponding to key switches 13a to 13d.

Operation designating operators 14a and 14b include key tops 141. Each key top 141 has a longitudinal shape extending along the side surface of housing 11, and its width is narrower than that of the side surface of housing 11. One end portion of each key top 141 (near the center of housing 11) is axially supported by an axis 142 to be a fixed end. Each axis 142 is inserted and held in an axis receiving portion 117 formed on the rear surface of upper half 111 of housing 11. The other end of each key top 141 is a free end. Therefore, the free end of each key top 141 can rotate about the axis 142. A portion near the free end of each key top 141 is rounded, so that it matches with the shape of the side surface of housing 11. Two sets of rubber contacts 143 are positioned opposing inner side surface near the free end of each key top in housing 11. The bottom surface of each rubber contact 143 provides a cavity as shown in Figs. 4 and 5, and a contact 144 is formed on the ceiling surface of the cavity. Each rubber contact 143 is contained and held in a corresponding holding member 145. Each holding member 145 is arranged at a position opposing an inner side surface near the free end of each key top 141, in housing 11. Each holding member 145 may be prepared as a member separate from housing 11. However, preferably, it is integrally formed on the rear surface of upper half 111 of housing 11, as in the present embodiment. Each holding member 145 holds each rubber contact 143, and serves as a stopper for limiting angle of rotation of each key top 141 in a prescribed range. As shown in Figs. 3 to 5, each holding member 145 is formed as a frame shaped projection having a groove to which the rubber contact 143 is inserted. A board (auxiliary board) 146 is arranged at a position opposing each rubber contact 143 and holding member 145. Each board 146 is inserted to notches

formed near left and right corners of the board 16, for example, and fixed to be vertical to the board 16. Contact circuits (not shown) corresponding to contacts 144 of the rubber contacts 143 are formed on the surface of board 146. When each key top 141 is rotated, rubber contact 143 is resiliently deformed, whereby each contact is brought into contact in parallel to the contact circuit on each board 146. The contact circuit formed on each board 146 is connected to a portion of a circuit pattern formed on board 16 through a lead 147.

Assembling step of the controller 10 for a game machine in accordance with the present invention will be described. First, as shown in Fig. 3, upper half 111 is placed with its rear surface facing upward. Then, from the rear surface side of upper half 111, key top 121 facing downward is inserted to hole 113. Thereafter, rubber contact 123 is placed on the bottom surface of key top 121. Thereafter, four key tops 131 facing downward are inserted to four holes 114 of upper half 111. Each key top 131 is positioned such that projection 132 provided on each key top 131 fits a groove formed on each guide projection 115. Thus insertion of each key top 131 to each hole 114 is facilitated. Thereafter, rubber contact 133 facing downward is placed on the bottom surface of each key top 131. Thereafter, each rubber contact 143 is inserted to each holding member 145. Then one end of each axis 12 is inserted to each axis receiving portion 117. Each axis 142 is inserted to a hole formed at a fixed end of each key top 141. Consequently, the fixed end of each key top 141 is axially supported by axis 142. Further, rubber contact 151 including select switch 15a and start switch 15b formed integrally is inserted to hole 118 of upper half 111, which rubber contact facing downward. Thereafter, board 16 is placed on rubber contacts 123 and 133, with each board 146 positioned opposing each holding member 145. Thereafter, lower half 112 is put on upper half 111, and lower half 112 is fixed to upper half 111 by means of screws.

As described above, in the present embodiment, four key switches 13a to 13d included in operation designating operator 13 are arranged in four directions which are crossing or orthogonally crossing. The key switches 13a to 13d can be used as direction designating switches designating upper, lower, left or right direction, based on program processing. In this case, controller 10 for a game machine can be used for a game which requires two different systems of direction designating operators. For example, in a game of controlling a tank, upper or lower projecting portion of the key top 121 of direction designating operator 12 may be depressed to designate forward or rearward rotation of left caterpillar of the tank. Key switches 13a or 13d of operation designating operator 13 may be

depressed to designate forward or rearward rotation of right caterpillar of the tank. In this case, when upper projection of key top 121 and key switch 13a are depressed, tank moves forward (advances). When lower projection of key top 121 and key switch 13d are depressed, the tank moves rearward. When upper projecting portion of key top 121 and key switch 13d are depressed, the tank turns to the left, and when lower projection of key top 121 and key switch 13a are depressed, the tank turns to the right. In such a tank game, operation designating operator 14 may be used to designate emission of missile or gun. In a game requiring only one system of direction designating operator, when operation designating operator 13 is used as the direction designating operator and direction designating operator 12 is used as operation designating operator by preparing an appropriate program, a controller for a game machine which is convenient for a left handed player can be provided.

Controller 10 for a game machine in the above described embodiment includes two key switches 14a and 14b provided on left and right sides of front side surface of housing 11, as operation designating operators 14. Alternatively, only one key switch may be provided on the right side or left side of front side surface of housing 11. Further, by making thick housing 11, two key switches may be arranged juxtaposed on the right side or left side of the front side surface of housing 11. Two key switches may be provided on each of the right and left sides of the front side surface of housing 11 (four switches in total). In that case, the key switches are operated by the index finger and middle finger of a player holding housing 11. Key top 141 of key switch 14a and key top 141 of key switch 14b may be formed as a coupled integral one key top, and the central portion of the key top may be axially supported by axis 142.

Methods of using controller 10 for a game machine of the above described embodiment, and effect thereof will be described in detail.

Fig. 6 shows the state of use of controller 10 for a game machine. Fig. 7 is a block diagram showing an example of a game machine system structure to which controller 10 for a game machine of the present embodiment is connected.

Controller 10 for a game machine of the present embodiment is used as shown in Fig. 6. More specifically, a player holds left and right ends of housing 11 with his left and right palms. In order to hold housing 11 stably, the player places his index fingers or middle fingers along the front side surface of housing 11. In this state, the player moves or changes inclination of his left thumb to depress any of upper, lower, left and right four projecting portions of the cross shaped key top

121. Thus direction of movement of a character or cursor displayed on a game screen (not shown) is designated. The player depresses key top of any of four key tops 13a to 13d while moving his right thumb. Thus a prescribed state of operation in the game is designated. Further, the player depresses key tops 141 of key switches 14a and 14b by his left and right index fingers or middle fingers. When a key top 141 is depressed by the inner portion of the index finger or middle finger, free end of key top 141 is depressed and rotated about the axially supported fixed end. Thus rubber contact 143 in housing 11 is resiliently deformed, and contact circuit formed on board 146 is short-circuited. Accordingly, an electric signal is provided from the contact circuit.

Referring to Fig. 7, a signal processing circuit 18 includes a shift register capable of parallel input and serial output. When a parallel write signal is applied from a microprocessor (CPU) 21 of game machine body 20, signal processing circuit 18 reads depression signals from direction designating operator 12, key switches 13a to 13d and 14a to 14b as parallel inputs, and stores and holds the same in the shift register. Then, when a serial read signal is applied from microprocessor 21 of game machine body 20, the signal processing circuit 18 serially outputs data stored in shift register in synchronization with a clock signal CL. Outputs from the shift register are applied to an I/O port 22 and loaded in I/O port 22. CPU 21 determines data indicating states of operation of controller 10 for a game machine loaded in I/O port 22 in accordance with a program set in a memory (ROM) 31 included in a game cartridge 30, and executes game processes in accordance with the result of determination. The game processing includes image processing for moving or changing a character displayed on a game screen, for example. Such image processing is executed by an image processing processor (PPU) 23 under control of CPU 21 in accordance with a program set in memory 31. At this time, a sound source circuit 24 generates analog signals for generating background music or sound effect under control of CPU 21 in accordance with the program set in memory 31.

A program may be adapted to allow a player to selectively set what function of designation should be allotted to key switches 13a to 13d included in operation designating operator 13 and to key switches 14a and 14b included in operation designating operator 14, at the start of the game.

Although the present invention has been described and illustrated in detail, it is clearly understood that the same is by way of illustration and example only and is not to be taken by way of limitation, the spirit and scope of the present invention being limited only by the terms of the appen-

ded claims.

Claims

- 5 1. A controller for a game machine used held between left and right palms, comprising:
 - a flat shaped housing (11) having an upper surface, a lower surface and a side surface spatially separating the upper and lower surfaces;
 - 10 upper surface operating means (12, 13) formed at a position on the upper surface of said housing where a thumb of a hand holding the housing can reach; and
 - 15 side surface operating means (14) formed at a position on the side surface of said housing where an index finger or a middle finger of the hand holding the housing can reach; wherein
 - 20 said side surface operating means includes
 - an elongate key top (141) axially supported and rotatable in said housing and positioned to have a portion thereof exposed along the side surface of said housing,
 - 25 switch means (143, 144, 146) contained in said housing for outputting an electric signal when it is depressed by rotation of said key top, and
 - 30 holding means (145) for holding said switch means at a position where it can be depressed by said key top, in said housing.
- 35 2. A controller for a game machine according to claim 1, wherein
 - said switch means includes
 - a rubber contact (122, 123) which is resiliently deformed in depressed direction when it is depressed by rotation of said key top, held by said holding means, and
 - 40 a first board (146) provided at a position facing said rubber contact, having a contact circuit which provides an electric signal by a contact with said rubber contact, when said rubber contact is depressed.
- 45 3. A controller for a game machine according to claim 2, further comprising
 - a second board (16) contained in said housing for providing an electric signal by an operation of said upper surface operating means, wherein
 - 50 said first board (146) is fixed engaged with said second board (16).
- 55 4. A controller for a game machine according to claim 2, wherein
 - said holding means is formed on rear sur-

face side of the upper surface of said housing, to have a shape of a frame for positioning and holding said rubber contact inserted therethrough, for limiting stroke of said key top.

means (13 or 12) gives a second operation designation of a character for the game, when it is operated.

- 5
5. A controller for a game machine according to claim 1, wherein
- said side surface operating means includes a side surface operating means (14a) for a left hand and a side surface operating means (14b) for a right hand arranged in symmetry on left and right of the side surface of said housing.
- 10
6. A controller for a game machine according to claim 5, wherein
- a key top (141) included in said side surface operating means (14a) for the left hand has its rotating portion tip end extended to a position where it can be depressed by the index finger or middle finger of the left hand holding said housing, and
- 20
- a key top (141) included in said side surface operating means (14b) for the right hand has its rotating portion tip end extended to a position where it can be depressed by the index finger or the middle finger of the right hand holding said housing.
- 25
7. A controller for a game machine according to claim 1, wherein
- said upper surface operating means includes first upper surface operating means (12 or 13) provided at a position where a thumb of one of the hands holding said housing can reach.
- 30
- 35
8. A controller for a game machine according to claim 7, wherein
- said first upper surface operating means (12 or 13) designates direction of movement of a character of the game, when it is operated.
- 40
9. A controller for a game machine according to claim 7, wherein
- said upper surface operating means further includes second upper surface operating means (13 or 12) provided at a position where a thumb of the other one of the hands holding said housing can reach.
- 45
- 50
10. A controller for a game machine according to claim 9, wherein
- said first upper surface operating means (12 or 13) gives a first operation designation of a character for the game, when it is operated, and
- 55
- said second upper surface operating

FIG. 1

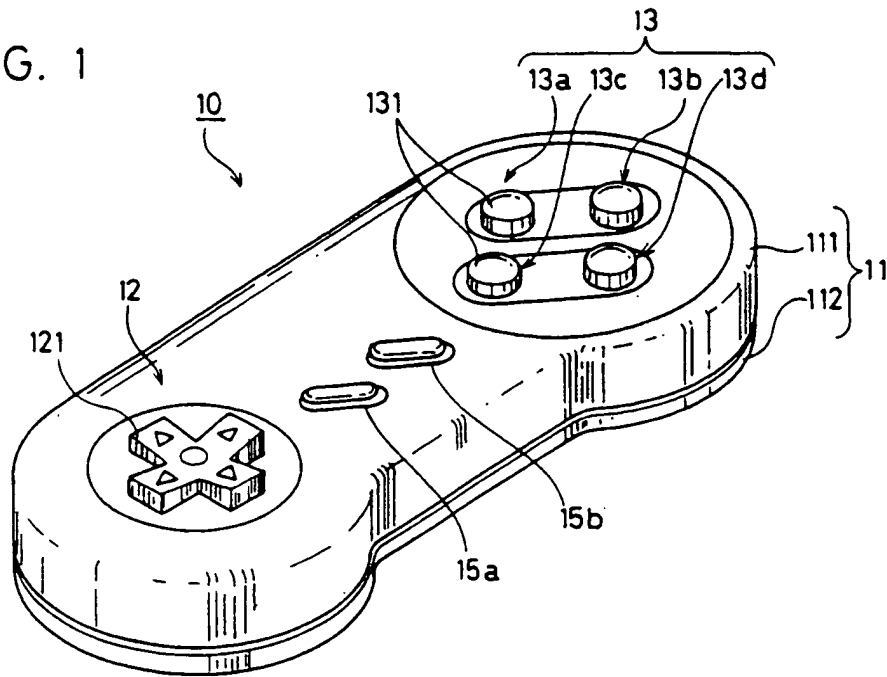

FIG. 2

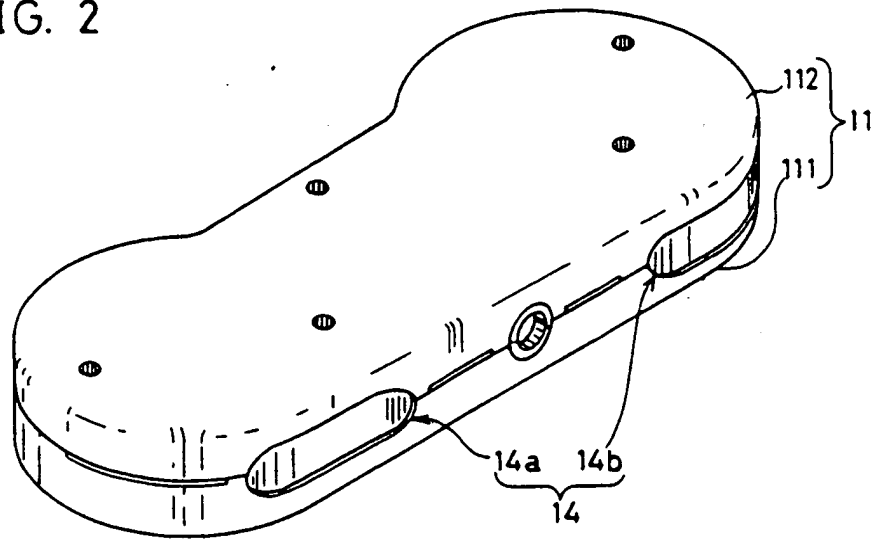

FIG. 3

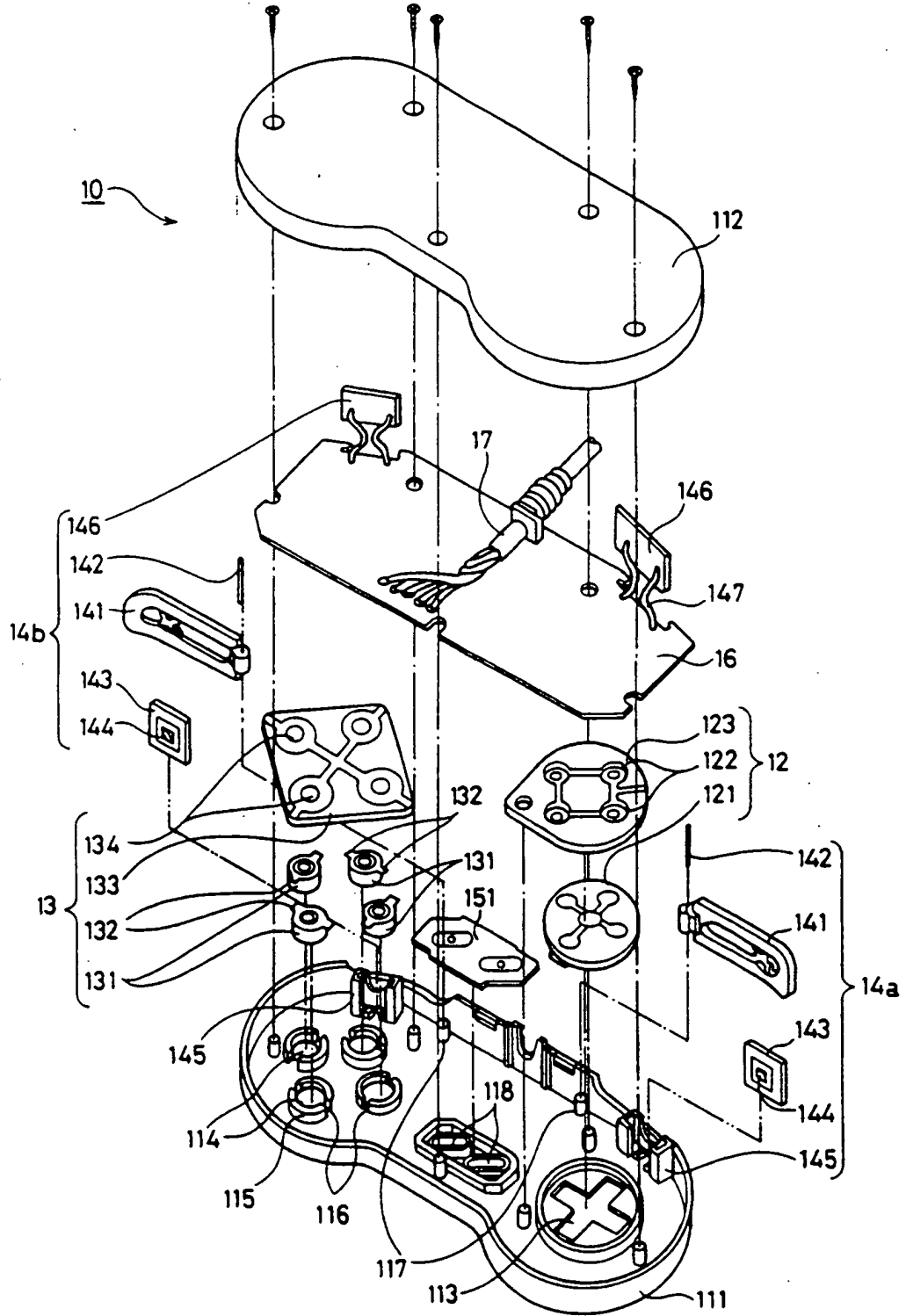

FIG.4

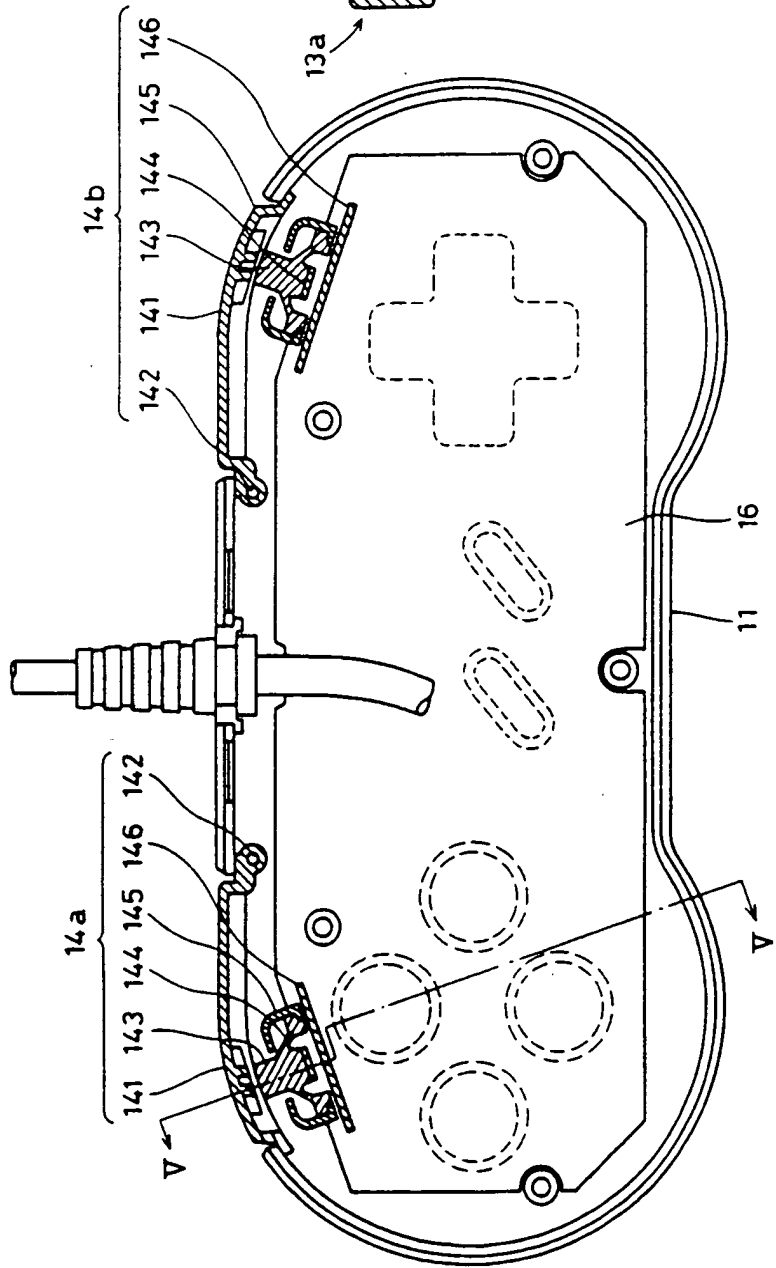

FIG.5

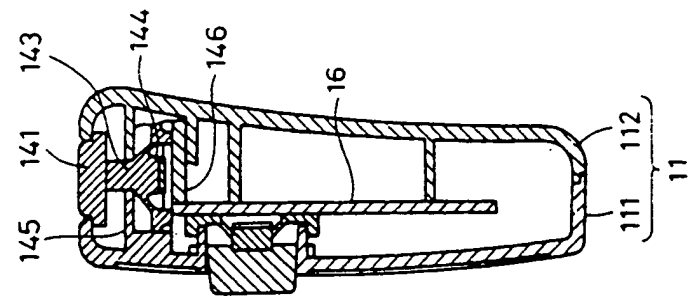

FIG. 6

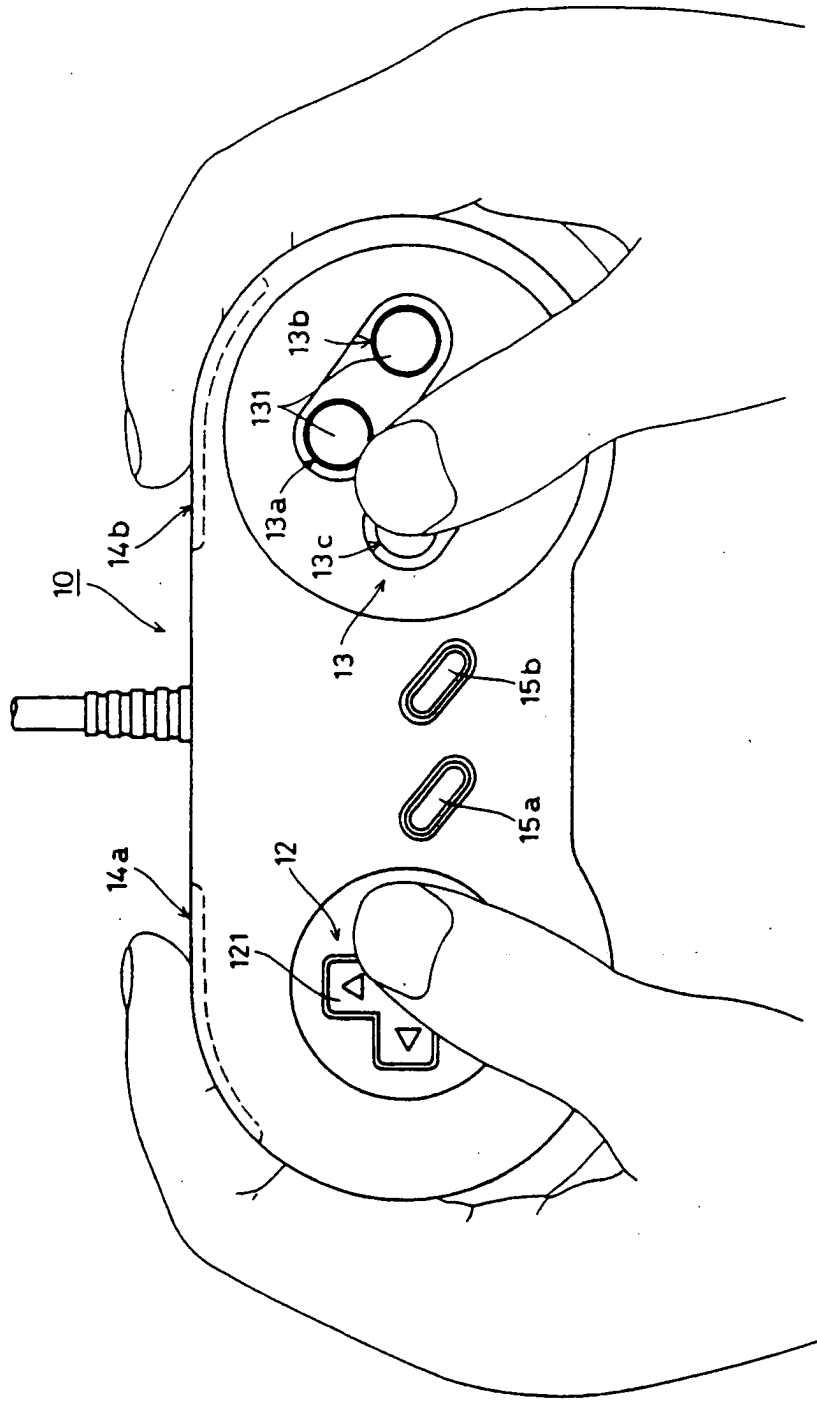
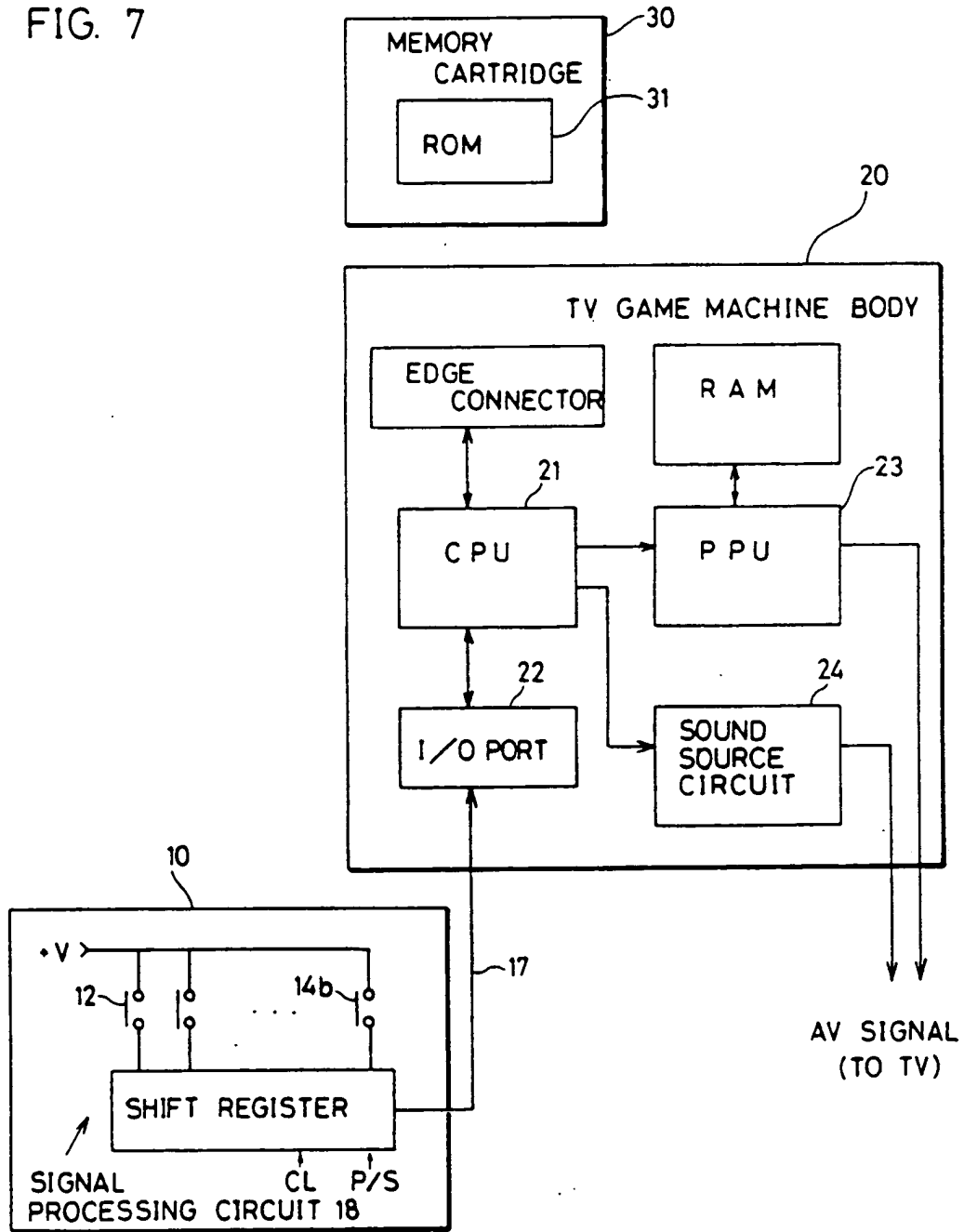

FIG. 7





European
Patent Office

EUROPEAN SEARCH
REPORT

Application Number

EP 91 11 3326

DOCUMENTS CONSIDERED TO BE RELEVANT			
Category	Citation of document with indication, where appropriate, of relevant passages	Relevant to claim	CLASSIFICATION OF THE APPLICATION (Int. Cl.5)
Y,A	FR-A-2 446 007 (MATTEL INC.) * page 5, line 32 - page 7, line 29; figure 1 * -----	1,2-10	H 01 H 13/70 G 06 F 3/023
Y	DE-A-1 810 119 (ALFERIEFF, N.) * page 2, paragraph 3 - page 3, paragraph 1 * * page 7, last paragraph - page 8, paragraph 4; figures 1, 2, 4 * -----	1	
A,D	DE-A-3 328 612 (NINTENDO CO. LTD.) * the whole document & US-A-4687200 * -----	1	
A	DE-A-2 517 573 (BEHN, C.) * claims 1-4 * -----	1	
			TECHNICAL FIELDS SEARCHED (Int. Cl.5)
			G 06 F H 01 H
The present search report has been drawn up for all claims			
Place of search		Date of completion of search	Examiner
Berlin		04 November 91	NIELSEN K G
<p>CATEGORY OF CITED DOCUMENTS</p> <p>X : particularly relevant if taken alone</p> <p>Y : particularly relevant if combined with another document of the same category</p> <p>A : technological background</p> <p>O : non-written disclosure</p> <p>P : intermediate document</p> <p>T : theory or principle underlying the invention</p> <p>E : earlier patent document, but published on, or after the filing date</p> <p>D : document cited in the application</p> <p>L : document cited for other reasons</p> <p>& : member of the same patent family, corresponding document</p>			